

SPECIFICATIONS:

MODEL NUMBER: 8090-902-278

PUMP DESIGN: Positive Displacement 3 Chamber Diaphragm Pump

CHECK VALVE: (2-Way Op) Prevents Reverse Flow & 6 Ft. Head Forward Flow

CAM: 2.5 Degree

MOTOR: Permanent Magnet, P/N 11-160-10, Thermally Protected

VOLTAGE: 230VAC Nominal

PRESSURE SWITCH: Adjustable Shut-Off (Range 80-110 PSI)

Factory Set @ 100 PSI, Turn On 75 PSI ± 5 PSI

LIQUID TEMPERATURE: 180 Degrees Fahrenheit (82 Degrees Centigrade) Max.

PRIME: Self-Priming Up To 9 Ft. Vertical,
Max. Inlet Pressure 30 PSI (2.1 Bar)

PORTS: 3/8"-18 NPT Female

MATERIAL OF CONSTRUCTION:

PLASTICS- Nylon

VALVES- EPDM

DIAPHRAGM- Santoprene

FASTENERS- Zinc Plated Steel

NET WEIGHT: 4.8 Lbs (2.18 Kg)

DUTY CYCLE: Intermittent (See Temperature Rise Chart)

TYPICAL APPLICATIONS: Soil Extraction

BYPASS: 100 PSI

APPROVALS: VDE Approved

MOTOR RATING: 50/60 Hertz

DIMENSIONS:

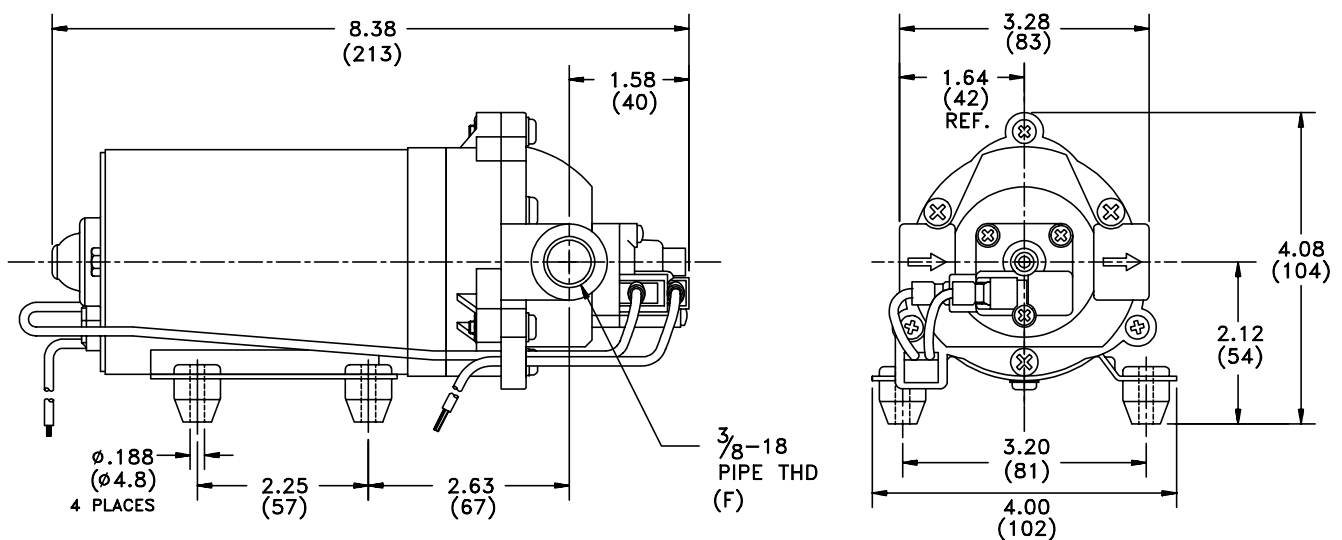

TEMPERATURE RISE

MODEL: 8090-902-278

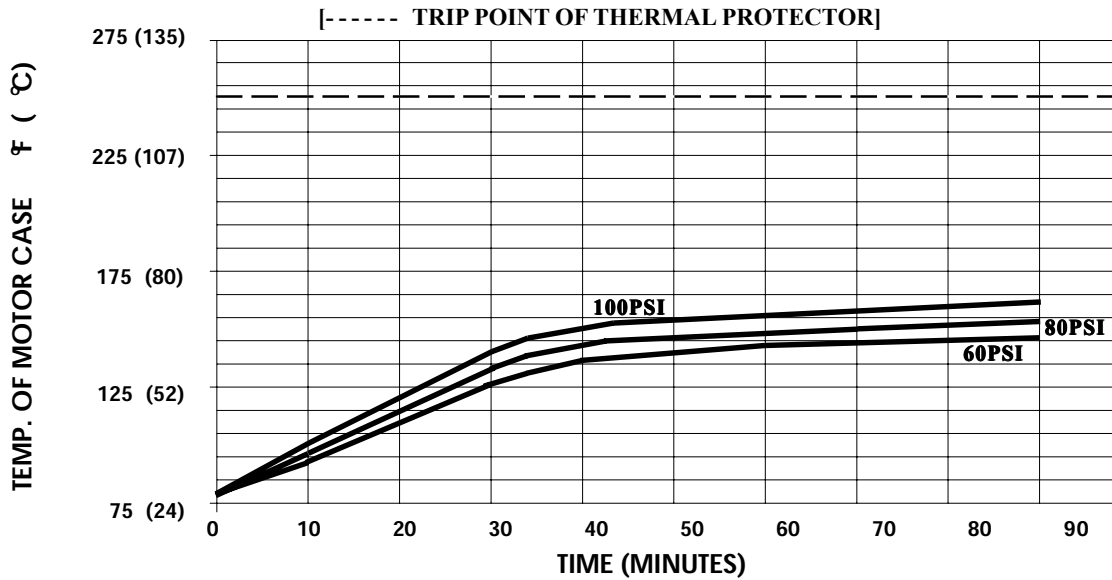

THIS GRAPH IS FOR USE AS A DESIGN GUIDE. IT IS BASED ON RUNNING CONTINUOUSLY WITH AN AMBIENT TEMPERATURE OF 80° F IN STILL AIR. THE THERMAL BREAKER WILL OPEN WHEN THE CASE TEMPERATURE REACHES 250° F.

TYPICAL PERFORMANCE

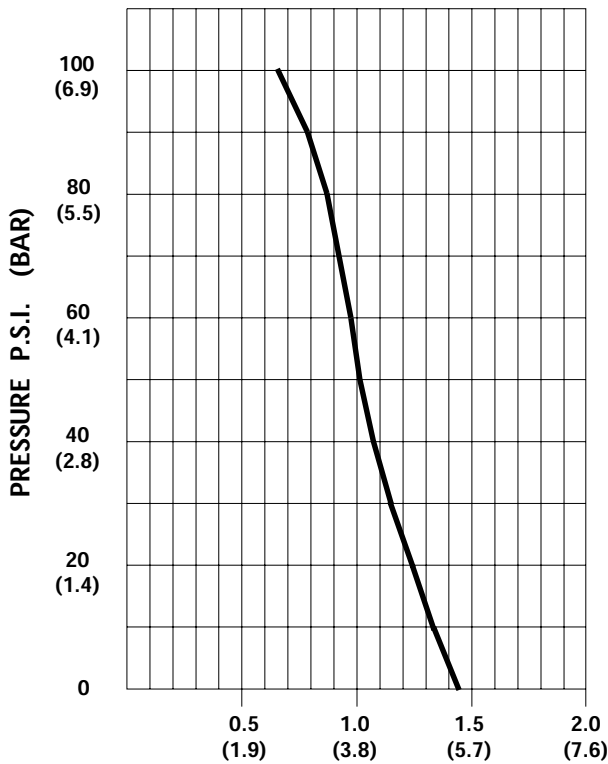

PRESSURE (PSI)	FLOW (GPM/LIT)	RPM MIN/MAX	CURRENT (AMPS)	VOLTAGE (VOLTS)
OPEN	1.44/5.4	2480/2585	0.16	230 VAC
10	1.33/5.0	2415/2485	0.18	"
20	1.23/4.6	2340/2410	0.20	"
30	1.16/4.4	2285/2350	0.21	"
40	1.08/4.1	2235/2290	0.23	"
50	1.02/3.9	2105/2245	0.25	"
60	0.97/3.7	2035/2180	0.26	"
70	0.92/3.5	1990/2135	0.28	"
80	0.87/3.3	1945/2085	0.30	"
90	0.79/3.0	1880/2045	0.32	"
100	0.65/2.5	1845/2005	0.33	"

FLOW - GALLONS PER MINUTE (LITERS PER MINUTE)

-SPECIFICATIONS SUBJECT TO CHANGE WITHOUT NOTICE.

-ALL DATA BASED ON TESTING WITH WATER AT AMBIENT TEMPERATURE.