

SPECIFICATIONS:

MODEL NUMBER: 8000-912-288

PUMP DESIGN: Positive Displacement 3 Chamber Diaphragm Pump

CHECK VALVE: (2-Way Op.) Prevents Reverse Flow and 6 Ft. Head Forward Flow

CAM: 2.5 Degree

MOTOR: Permanent Magnet, P/N 11-150-10, Thermally Protected

VOLTAGE: 115 VAC Nominal

PRESSURE SWITCH: Adjustable Shut-Off (Range 85-105 PSI)

Factory Set @105 PSI, Turn On 85 PSI ±5 PSI

LIQUID TEMPERATURE: 180 Degrees Fahrenheit (82 Degrees Centigrade) Max.

PRIME: Self-Priming Up To 6.5 Ft. Vertical,
Max. Inlet Pressure 30 PSI (2.1 Bar)

PORTS: 3/8"-18 NPT, Female

MATERIAL OF CONSTRUCTION:

PLASTICS- Nylon

VALVES- EPDM

DIAPHRAGM- Santoprene

FASTENERS- Zinc or Cad Plated Steel

NET WEIGHT: 4.9 Lbs (2.2 Kg)

DUTY CYCLE: Intermittent (See Temperature Rise Chart)

APPROVALS: UL/CSA Recognized

TYPICAL APPLICATIONS: Soil Extraction

BYPASS: 80 PSI

DIMENSIONS:

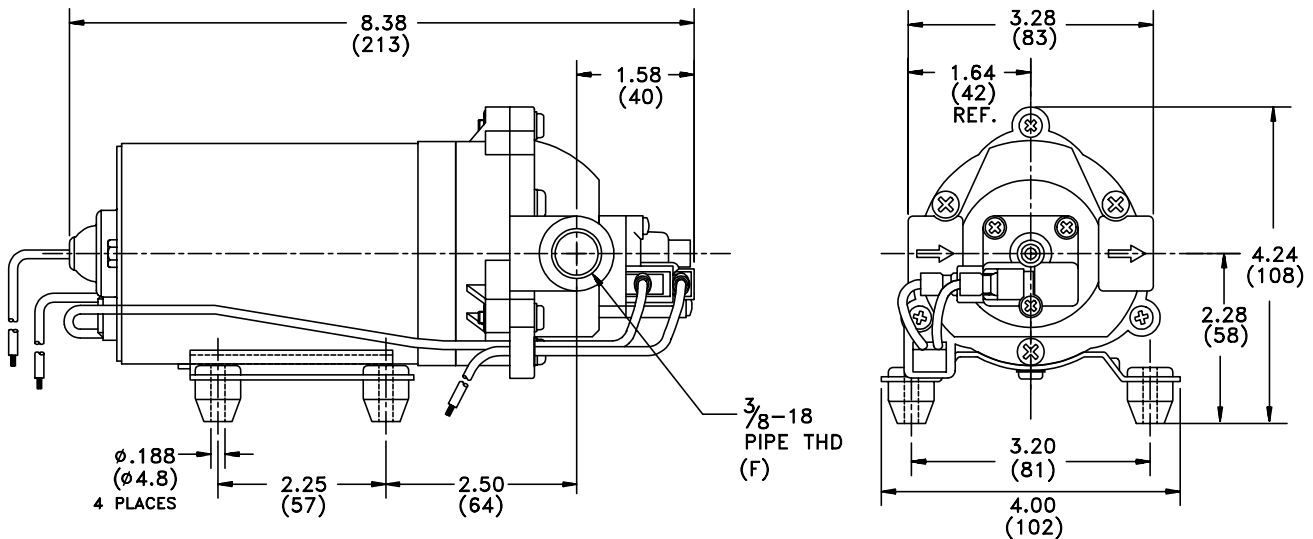

TEMPERATURE RISE

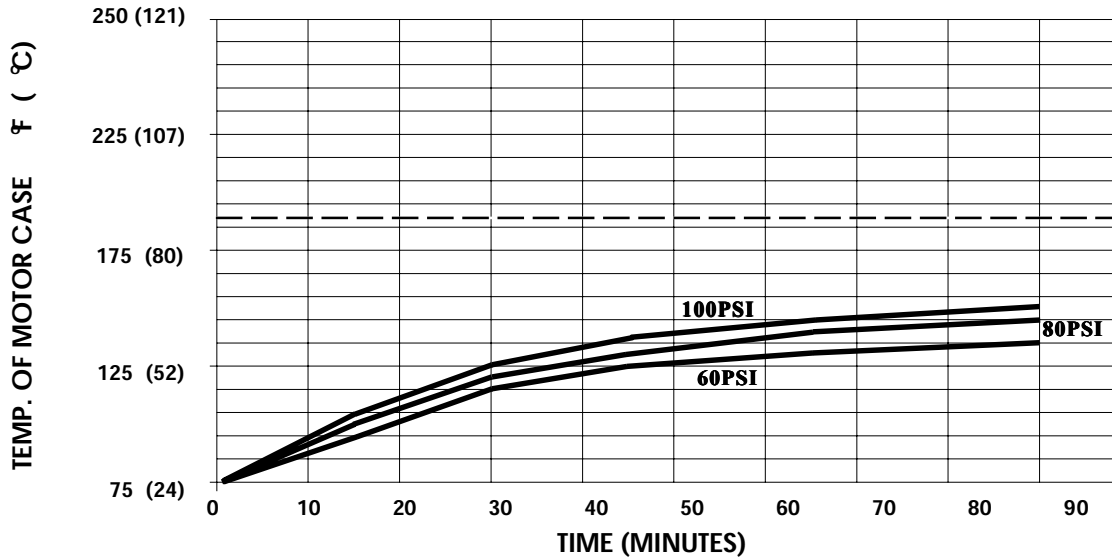

THIS GRAPH IS FOR USE AS A DESIGN GUIDE. IT IS BASED ON RUNNING CONTINUOUSLY WITH AN AMBIENT TEMPERATURE OF 70° F IN STILL AIR. THE THERMAL BREAKER WILL OPEN WHEN THE CASE TEMPERATURE REACHES 190° F.

[----- TRIP POINT OF THERMAL PROTECTOR]

TYPICAL PERFORMANCE

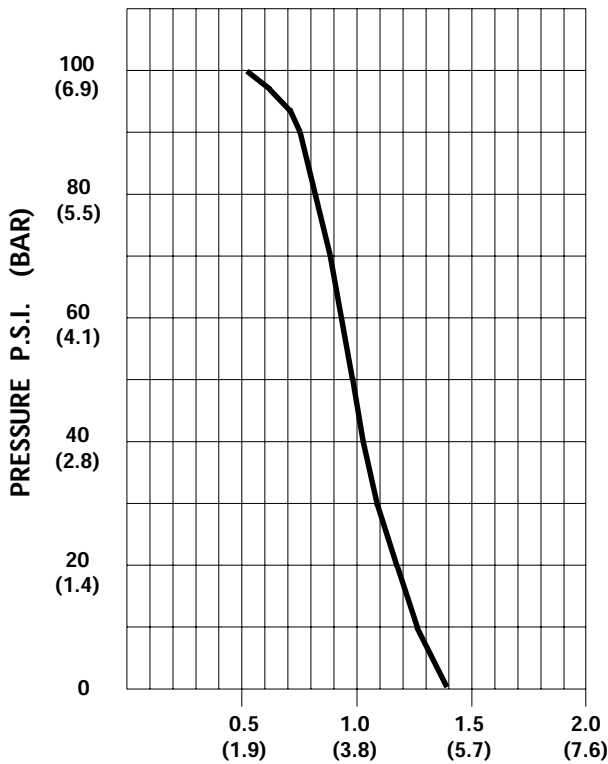

PRESSURE (PSI)	FLOW (GPM/LIT)	RPM MIN/MAX	CURRENT (AMPS)	VOLTAGE (VOLTS)
OPEN	1.40/5.3	2195/2290	0.31	115 VAC
10	1.26/4.8	2185/2215	0.36	"
20	1.19/4.5	2100/2160	0.41	"
30	1.12/4.2	2035/2100	0.45	"
40	1.04/3.9	1975/2050	0.49	"
50	0.95/3.6	1940/2000	0.53	"
60	0.93/3.5	1890/1950	0.56	"
70	0.89/3.4	1850/1915	0.60	"
80	0.84/3.2	1805/1875	0.63	"
90	0.74/2.8	1775/1850	0.65	"
100	0.51/1.9	1735/1810	0.68	"

-SPECIFICATIONS SUBJECT TO CHANGE WITHOUT NOTICE.

-ALL DATA BASED ON TESTING WITH WATER.