

SPECIFICATIONS:

MODEL NUMBER: 8000-543-290
PUMP DESIGN: Positive Displacement 3 Chamber Diaphragm Pump
CAM: 3.0 Degree
MOTOR: Permanent Magnet, P/N 11-111-00
VOLTAGE: 12VDC Nominal
PRESSURE SWITCH: None (1/4"-18 NPT Female Front Fitting Connection)
LIQUID TEMPERATURE: 170 Degrees Fahrenheit (77 Degrees Centigrade) Max.
PRIME: Self-Priming Up To 5 Ft. Vertical,
 Max. Inlet Pressure 30 PSI (2.1 Bar)
PORTS: 3/8"-18 NPT Female
MATERIAL OF CONSTRUCTION:
PLASTICS- Polypropylene
VALVES- Viton
DIAPHRAGM- Santoprene
FASTENERS- Zinc Plated Steel
NET WEIGHT: 4.0 Lbs (1.8 Kg)
DUTY CYCLE: Continuous (See Temperature Rise Chart)
TYPICAL APPLICATIONS: Agricultural Spraying

DIMENSIONS:

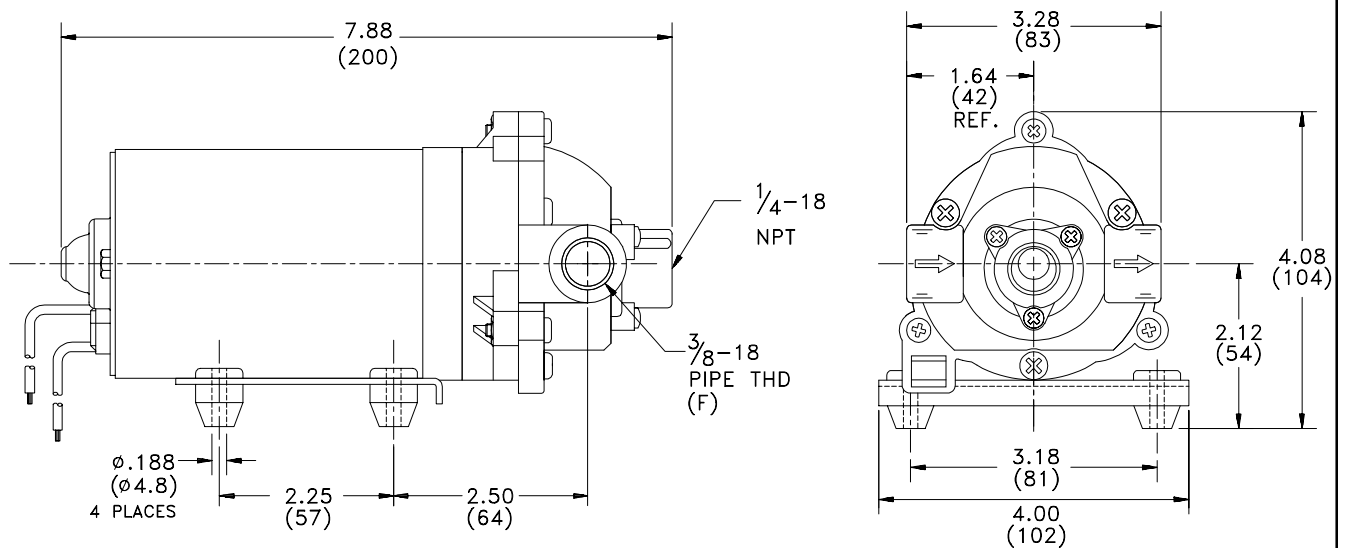

TEMPERATURE RISE

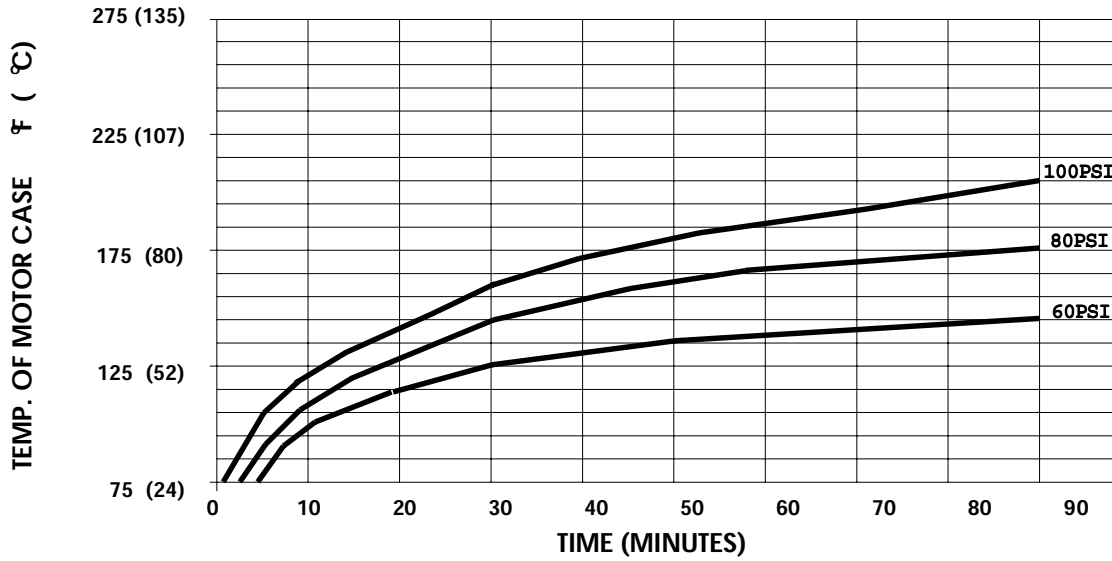

TYPICAL PERFORMANCE

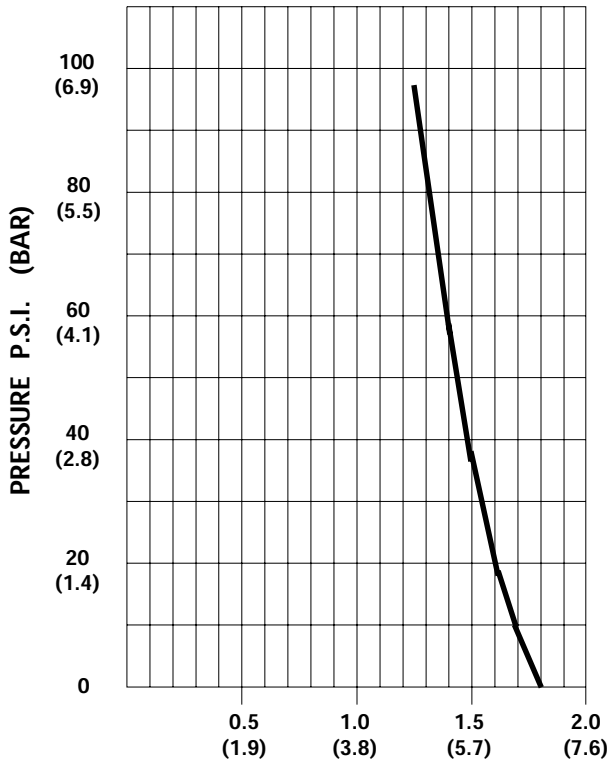

PRESSURE (PSI)	FLOW (GPM/LIT)	RPM MIN/MAX	CURRENT (AMPS)	VOLTAGE (VOLTS)
OPEN	1.8/6.8	2300/2375	3.7	12VDC
10	1.31/4.9	2260/2290	4.4	"
20	1.26/4.7	2215/2240	5.0	"
30	1.20/4.5	2175/2190	5.7	"
40	1.14/4.3	2130/2145	6.2	"
50	1.08/4.1	2085/2095	6.8	"
60	1.02/3.9	2050/2065	7.3	"
70	0.97/3.7	2015/2030	7.7	"
80	0.93/3.5	1965/1995	8.0	"
90	0.89/3.4	1935/1960	8.4	"
100	0.84/3.2	1885/1920	8.8	"

-SPECIFICATIONS SUBJECT TO CHANGE WITHOUT NOTICE.

-ALL DATA BASED ON TESTING WITH WATER AT AMBIENT TEMPERATURE.