

SPECIFICATIONS:

- MODEL NUMBER:** 8000-543-250
- PUMP DESIGN:** Positive Displacement 3 Chamber Diaphragm Pump
- CAM:** 3.0 Degree
- MOTOR:** Permanent Magnet, P/N 11-111-00
- VOLTAGE:** 12 VDC Nominal
- PRESSURE SWITCH:** None
- LIQUID TEMPERATURE:** 170 Degrees Fahrenheit (77 Degrees Centigrade) Max.
- PRIME:** Self-Priming Up To 11 Ft. Vertical,
 Max. Inlet Pressure 30 PSI (2.1 Bar)
- PORTS:** 3/8"-18 NPT Female
- MATERIAL OF CONSTRUCTION:**
 - PLASTICS-** Polypropylene
 - VALVES-** Viton
 - DIAPHRAGM-** Santoprene
 - FASTENERS-** Cad or Zinc Plated Steel
- NET WEIGHT:** 4.0 Lbs (1.8 Kg)
- DUTY CYCLE:** Continuous (See Temperature Rise Chart)
- TYPICAL APPLICATIONS:** Agricultural Spraying
- BYPASS:** 45 PSI

DIMENSIONS:

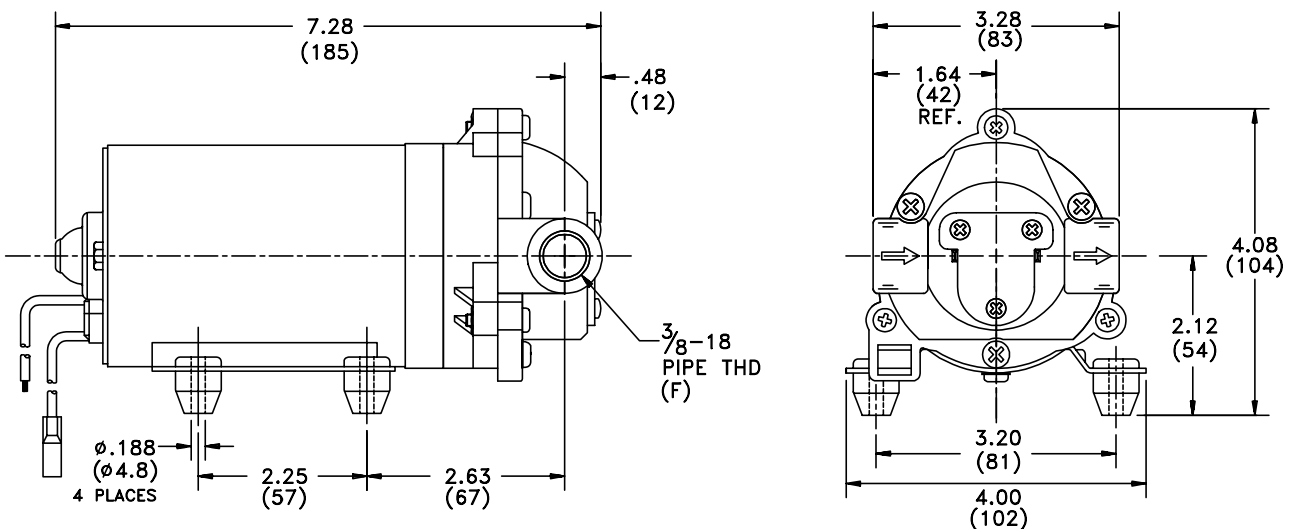

TEMPERATURE RISE

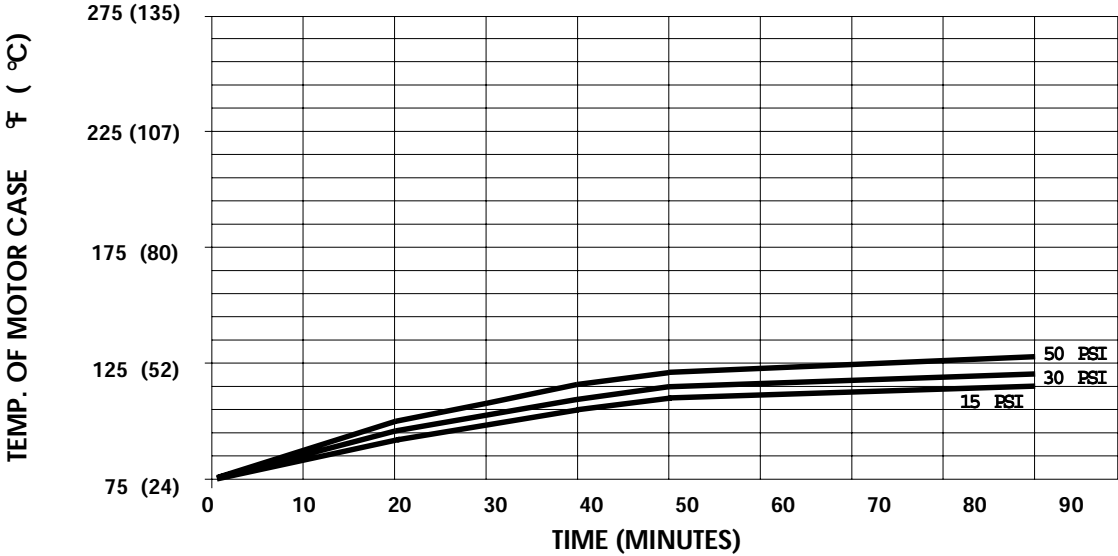

TYPICAL PERFORMANCE

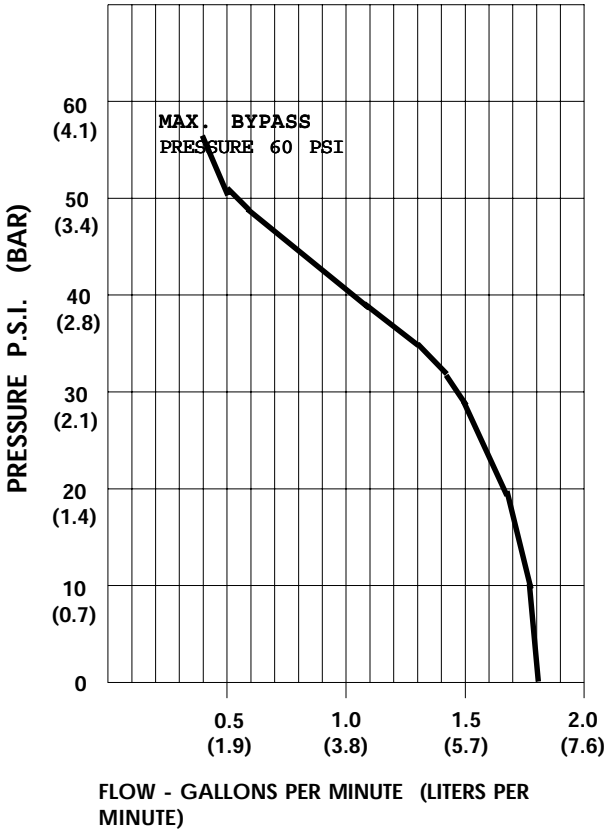

PRESSURE (PSI)	FLOW (GPM/LIT)	RPM MIN/MAX	CURRENT (AMPS)	VOLTAGE (VOLTS)
OPEN	1.8/6.8	2290/2345	3.0	12 VDC
10	1.40/5.3	2275/2335	3.4	"
20	1.30/4.9	2230/2300	4.0	"
30	1.11/4.2	2190/2255	4.7	"
40	0.69/2.6	2165/2230	5.2	"
50	0.18/0.7	2140/2200	5.5	"

*-SPECIFICATIONS SUBJECT TO CHANGE WITHOUT NOTICE.
 -ALL DATA BASED ON TESTING WITH WATER AT AMBIENT TEMPERATURE.*