

SPECIFICATIONS:

MODEL NUMBER: 100-000-20

PUMP DESIGN: Positive Displacement Wobbler Pump

MOTOR: Permanent Magnet, P/N 11-144-01

VOLTAGE: 12VDC Nominal

LIQUID TEMPERATURE: 130 Degrees Fahrenheit (54 Degrees Centigrade) Max.

PRIME: Self-Priming Up To 4 in. Vertical,
Max. Inlet Pressure 30 PSI (2.1 Bar)

PORTS: 3/8" Barb

MATERIAL OF CONSTRUCTION:

PLASTICS- Polyphenylene Sulfide

ELASTOMERS- Nitrile-Butadiene

FASTENERS- Zinc Plated Steel

NET WEIGHT: 0.5 Lbs (0.2 Kg)

DUTY CYCLE: Intermittent (See Temperature Rise Chart)

TYPICAL APPLICATIONS: Potable Water

DIMENSIONS:

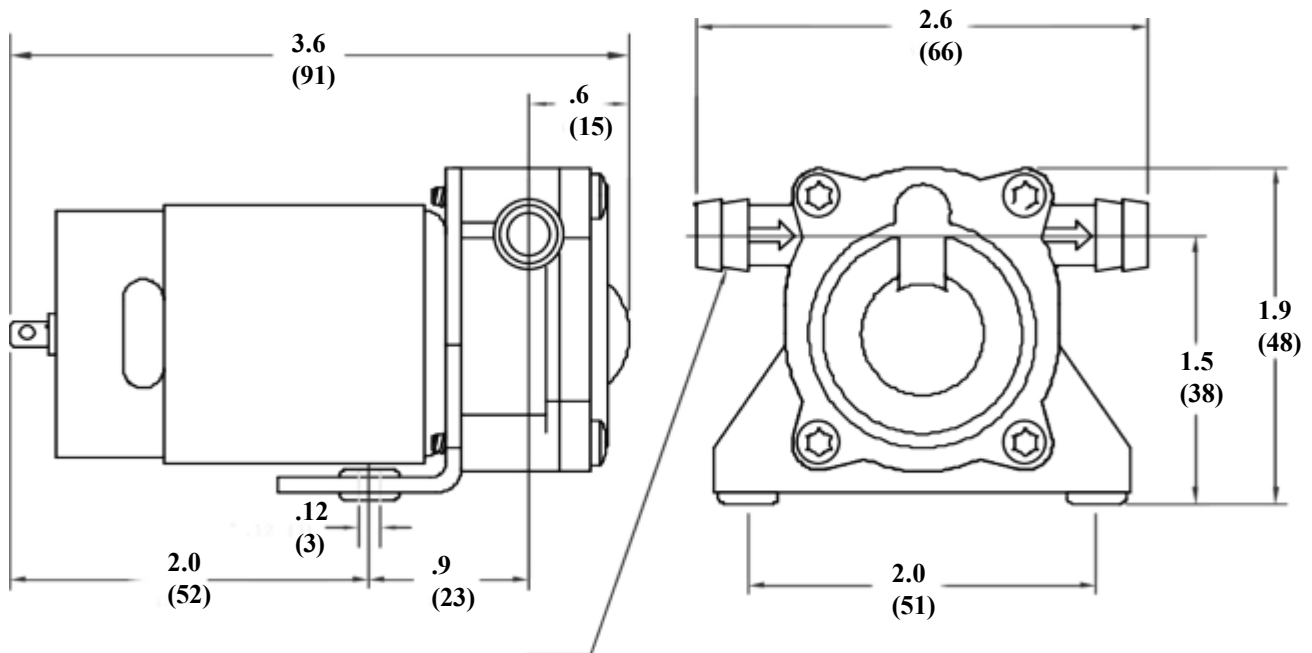

TEMPERATURE RISE

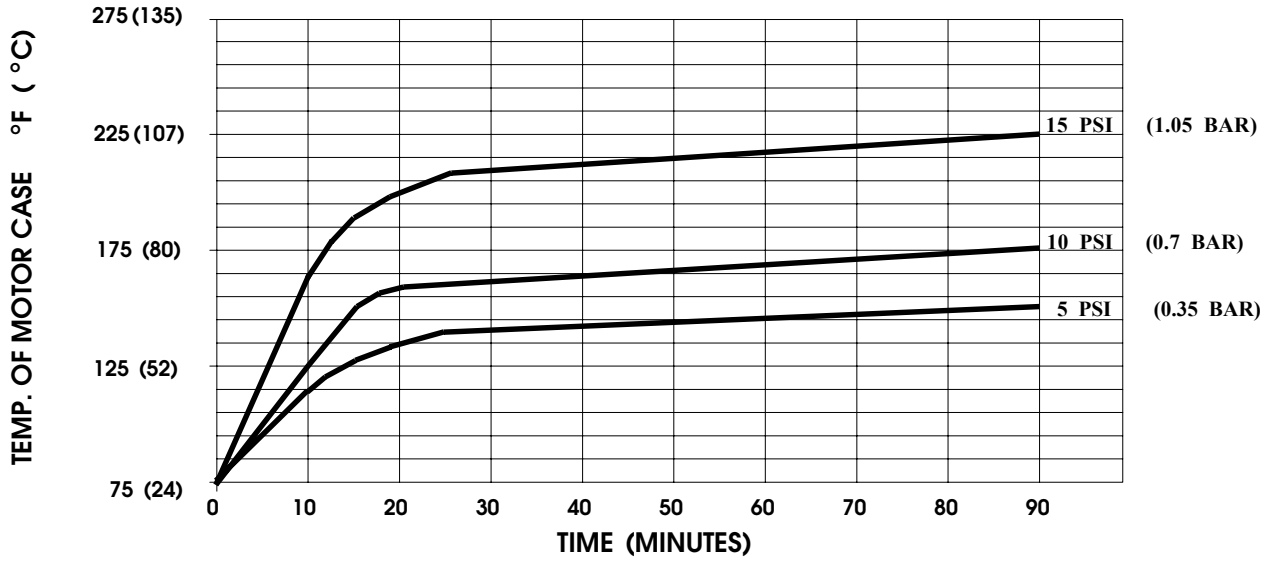

THIS GRAPH IS FOR USE AS A DESIGN GUIDE. IT IS BASED ON RUNNING CONTINUOUSLY WITH AN AMBIENT TEMPERATURE OF 75° F (24°C) IN STILL AIR.

TYPICAL PERFORMANCE

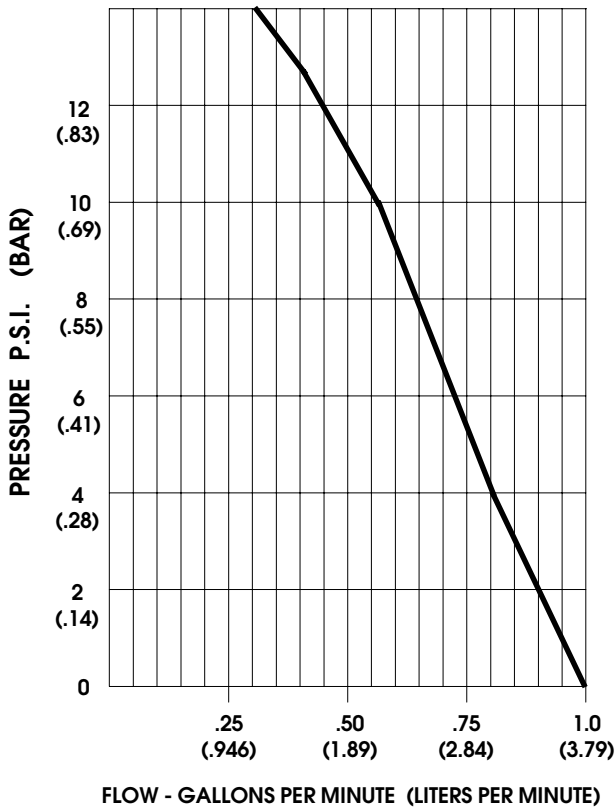

PRESSURE (PSI/BAR)	FLOW (GPM/LIT)	RPM MIN/MAX	CURRENT (AMPS)	VOLTAGE (VOLTS)
OPEN	1.00/3.8	2000/2055	1.5	12VDC
5/0.35	0.80/3.0	1935/1985	1.7	"
10/0.70	0.56/2.1	1840/1860	2.0	"
15/1.05	0.26/1.0	1670/1705	2.4	"

*-SPECIFICATIONS SUBJECT TO CHANGE WITHOUT NOTICE.
-ALL DATA BASED ON TESTING WITH WATER.*